



REFRIGERATED CONTAINERS

2018



Öztiryakiler

Founded in 1958, Öztiryakiler (Ozti) is a leading Turkish manufacturer of Commercial Catering Equipment and Defense Industry Logistic Support Systems.

The company manufactures and exports more than 4500 different kind of high quality products and also offers complete turnkey projects with over 60 years of experience .

Its 150,000 m2 modern plants regroup all the production steps with a staff of nearly 1300 workers.

Öztiryakiler is among the most successful Turkish exporter companies and has worldwide references in more than 130 countries.

Being the main supplier of the Turkish Military Forces, Öztiryakiler has developed highly innovative product line consisting of Field Catering Solutions and various Field Utilities for militaries deployed around the world.

These products are designed for rapid deployment and they are mainly based on two different supports: trailers and containers.

Öztiryakiler can provide customized state-of-the-art solutions to meet all military requirements, as well as the needs of civilian users such as humanitarian aid organizations.

With over 1000 units serving in many countries Öztiryakiler military products have proven themselves on their capability and high quality.

Some of our references: Georgia, US Army TACOM LGMC , Azerbaijan, Malaysia, Kingdom of Saudi Arabia, Iraq Ministry of Defense, Royal Thai Marine corps, Paraguay, Russia, UAE, Italy, Mauritania. Zimbabwe...



REFRIGERATION, FREEZING & FOOD
STORAGE

REFRIGERATED CONTAINER

OZTI refrigerated containers are specially designed and developed for the cooling, freezing and storage of food. Units can be offered with different specifications and room sizes depending on the requirements. All interior is clad in stainless steel. OZTI refrigerated containers can be transported by air, sea, rail or road transport as a standard shipping container.



High Quality Panels



Environment Friendly



Fire Retardant



Largest Production

20 Ft. Freezer

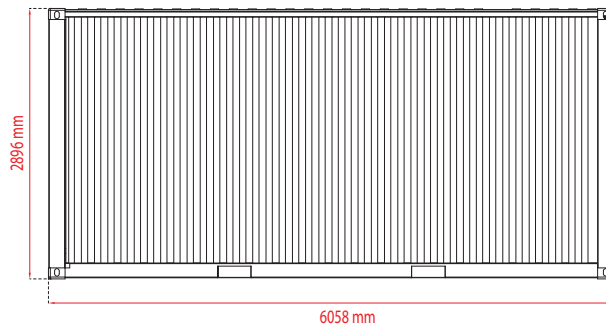
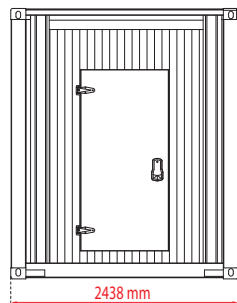

Generator

Information:

Diesel Generator: 20 kVA

Output Power: 20.3 kVA Prime

Dimensions (LxWxH): 650x1450x1150 mm

Engine: Perkins

No. of Cylinders: 4

Operating speed: 1500 rpm

Fuel Consumption: 6.1 Lt./h

Fuel Capacity: 75 Lt.

Freezer Evaporator

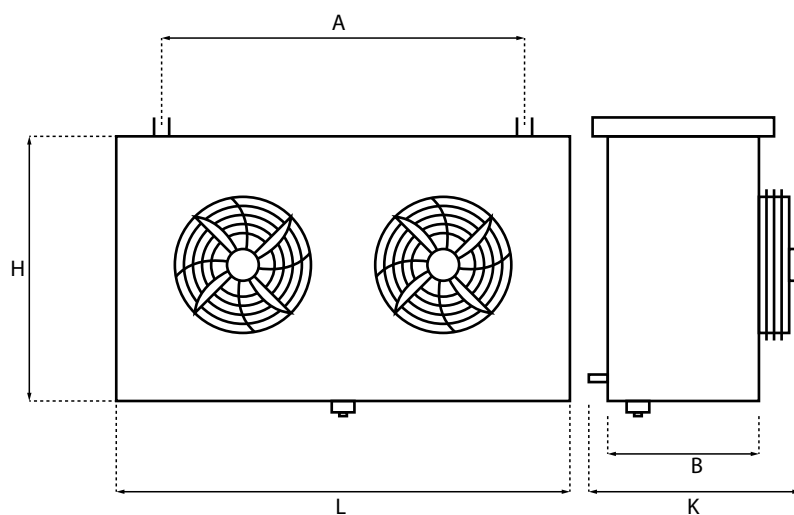

MODEL	DIMENSIONS				
	A	L	H	K	B
KES 302	835 mm	1125 mm	430 mm	470 mm	290 mm

Information:

Evap Code: EDF-300

Evap Type: CUBIC

Evap Capacity: 3300 W.

Evap Supplier: Kontherm or Equal

Freezer Condenser & Compressor

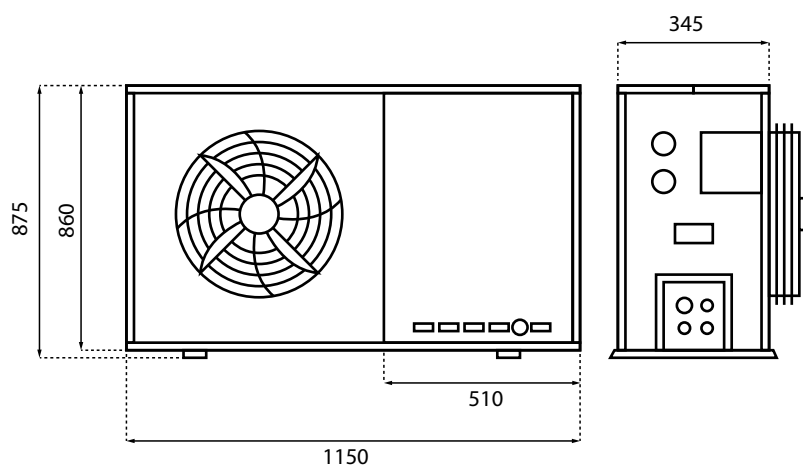

Information:

Compressor Brand: Bitzer / 3 hp Semi Hermetic

Compressor Type: Air

Cooling Capacity: 2891 W.

20 Ft. Reefer

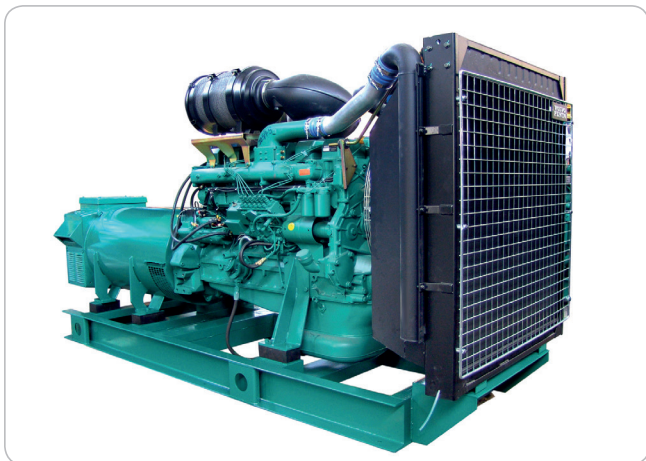
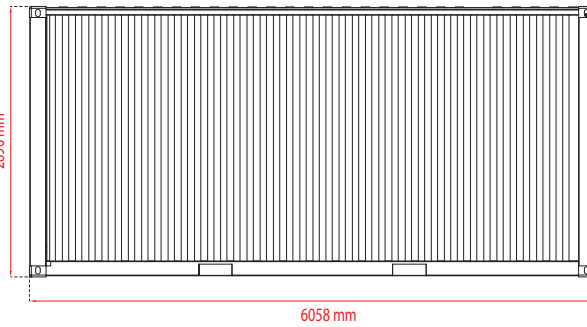
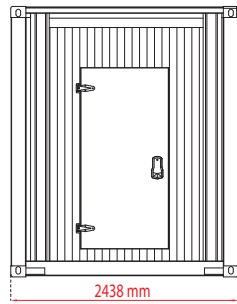

Generator

Information:

- Diesel Generator: 20 kVA
- Output Power: 20.3 kVA Prime
- Dimensions (LxWxH): 650x1450x1150 mm
- Engine: Perkins
- No. of Cylinders: 4
- Operating speed: 1500 rpm
- Fuel Consumption: 6.1 Lt./h
- Fuel Capacity: 75 Lt.

Reefer Evaporator

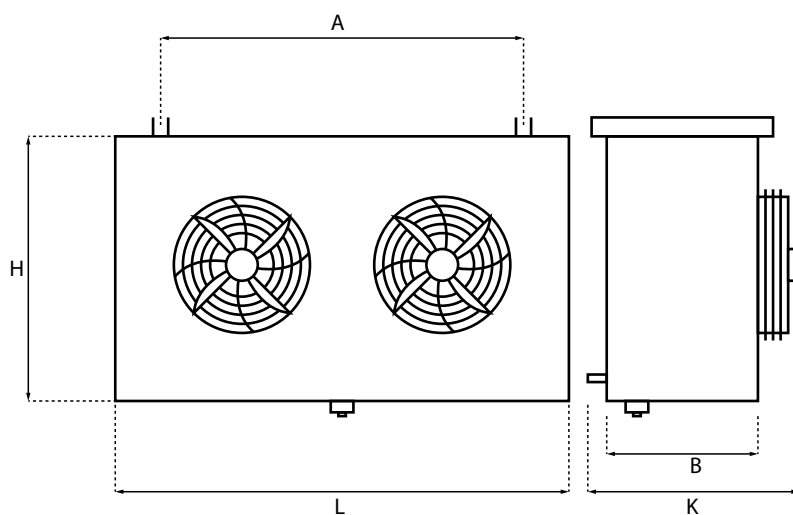

MODEL	DIMENSIONS				
	A	L	H	K	B
KES 351	535 mm	815 mm	520 mm	470 mm	290 mm

Information:

Evap Code: ECR- 200

Evap Type: CUBIC

Evap Capacity: 3850 W.

Evap Supplier: Kontherm or Equal

Reefer Condenser & Compressor

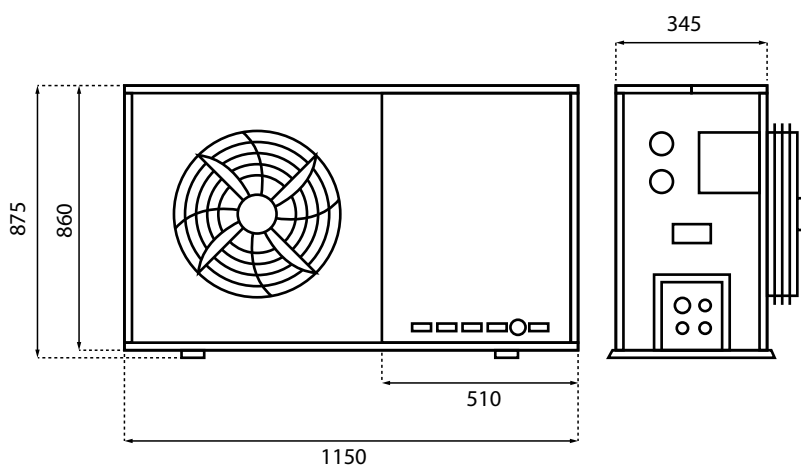

Information:

Compressor Brand: Bitzer / 2 hp Semi Hermetic

Compressor Type: Air

Cooling Capacity: 3178 W.

• We are constantly improving our products and therefore reserve the right to change design and specifications without prior notice.

20 Ft. Freezer - Reefer Model 1

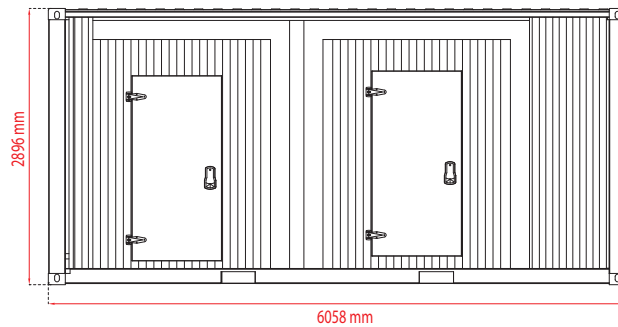
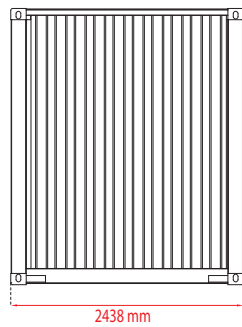
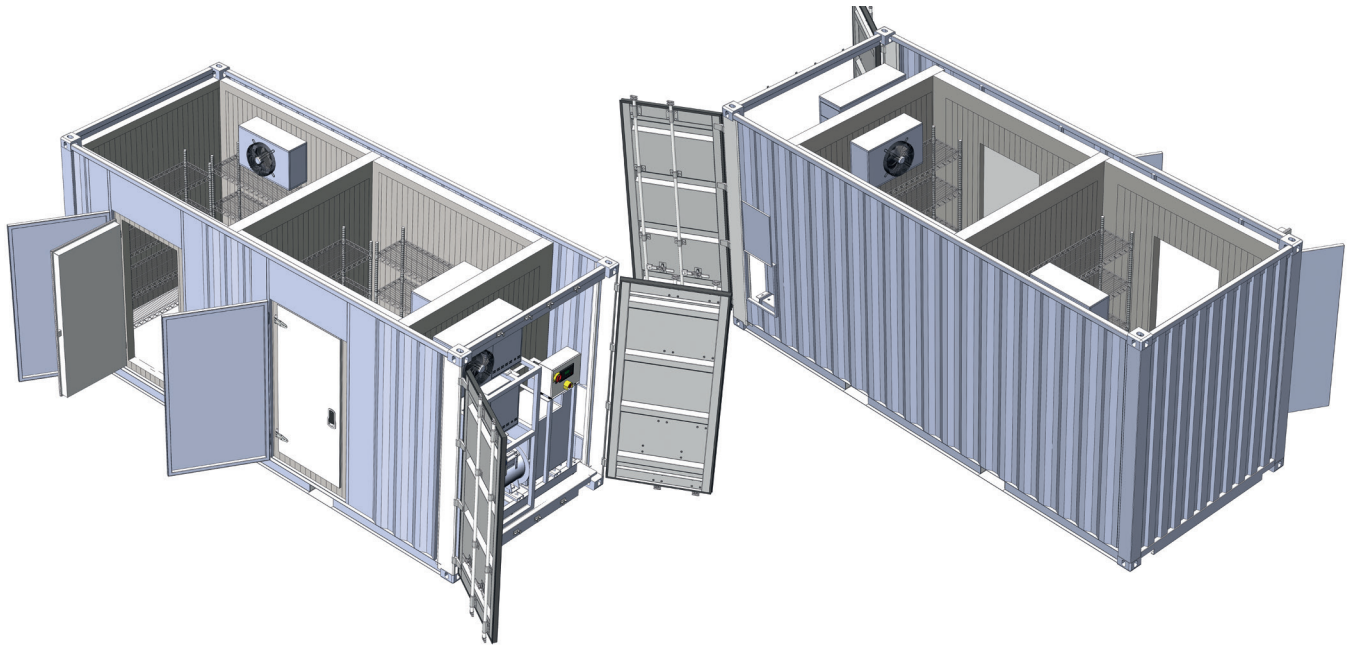

Generator

Information:

Diesel Generator: 20 kVA

Output Power: 20.3 kVA Prime

Dimensions (LxWxH): 650x1450x1150 mm

Engine: Perkins

No. of Cylinders: 4

Operating speed: 1500 rpm

Fuel Consumption: 6.1 Lt./h

Fuel Capacity: 75 Lt.

Freezer-Reefer Evaporator

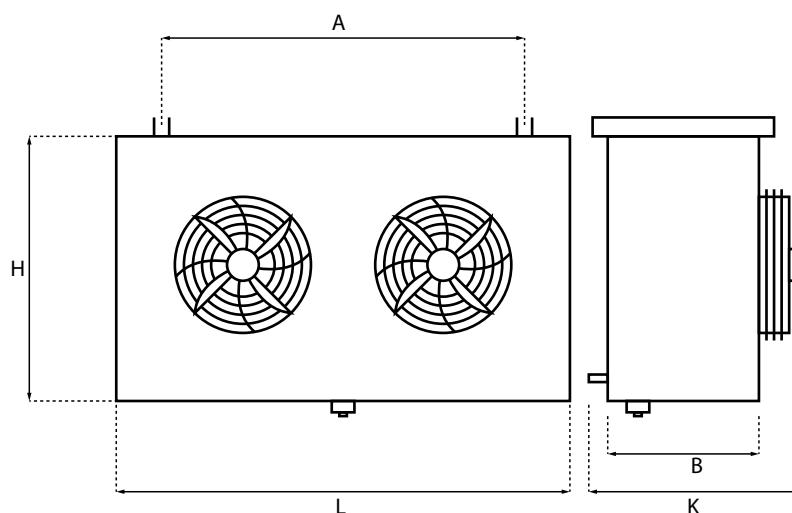

FREEZER					
MODEL	DIMENSIONS				
	A	L	H	K	B
KES 302	835 mm	1125 mm	430 mm	470 mm	290 mm

Information:

Evap Code: EDF-300

Evap Type: CUBIC

Evap Capacity: 3300 W.

Evap Supplier: Kontherm or Equal

REEFER					
MODEL	DIMENSIONS				
	A	L	H	K	B
KES 351	535 mm	815 mm	520 mm	470 mm	290 mm

Information:

Evap Code: ECR-200

Evap Type: CUBIC

Evap Capacity: 3850 W.

Evap Supplier: Kontherm or Equal

Freezer-Reefer condenser & compressor

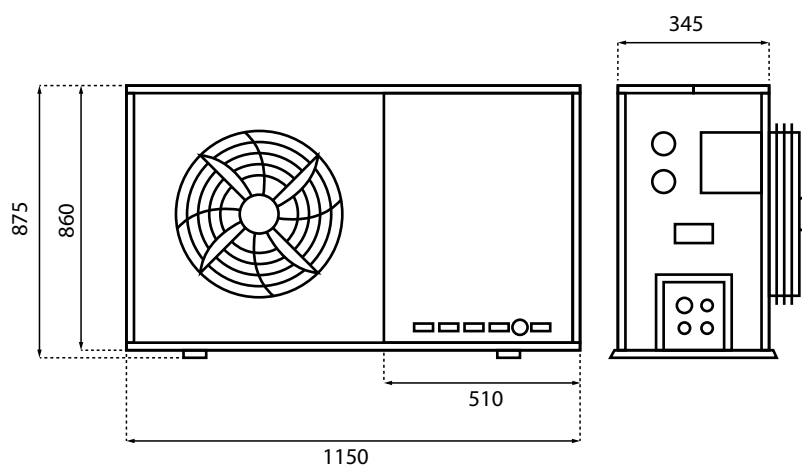

Freezer Information:

Compressor Brand: Bitzer / 3 hp Semi Hermetic

Compressor Type: Air

Cooling Capacity: 2891 W.

Reefer Information:

Compressor Brand: Bitzer / 2 hp Semi Hermetic

Compressor Type: Air

Cooling Capacity: 3178 W.

20 Ft. Freezer-Reefer Model 2

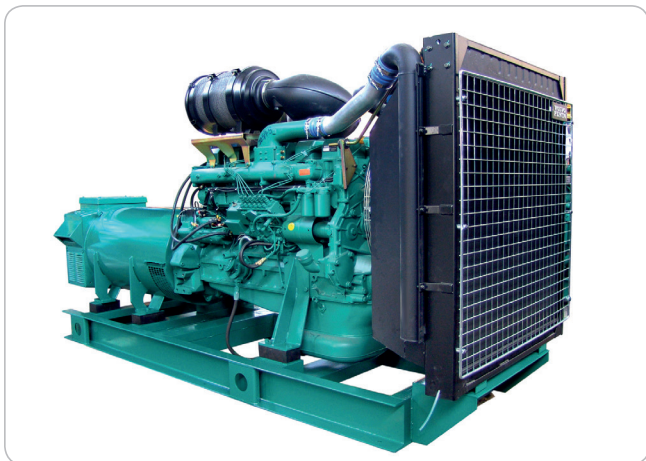
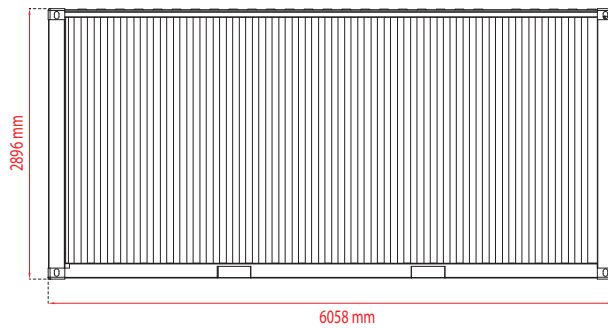
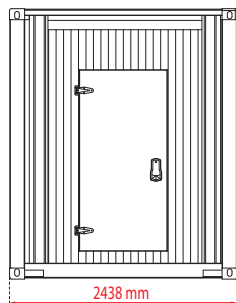
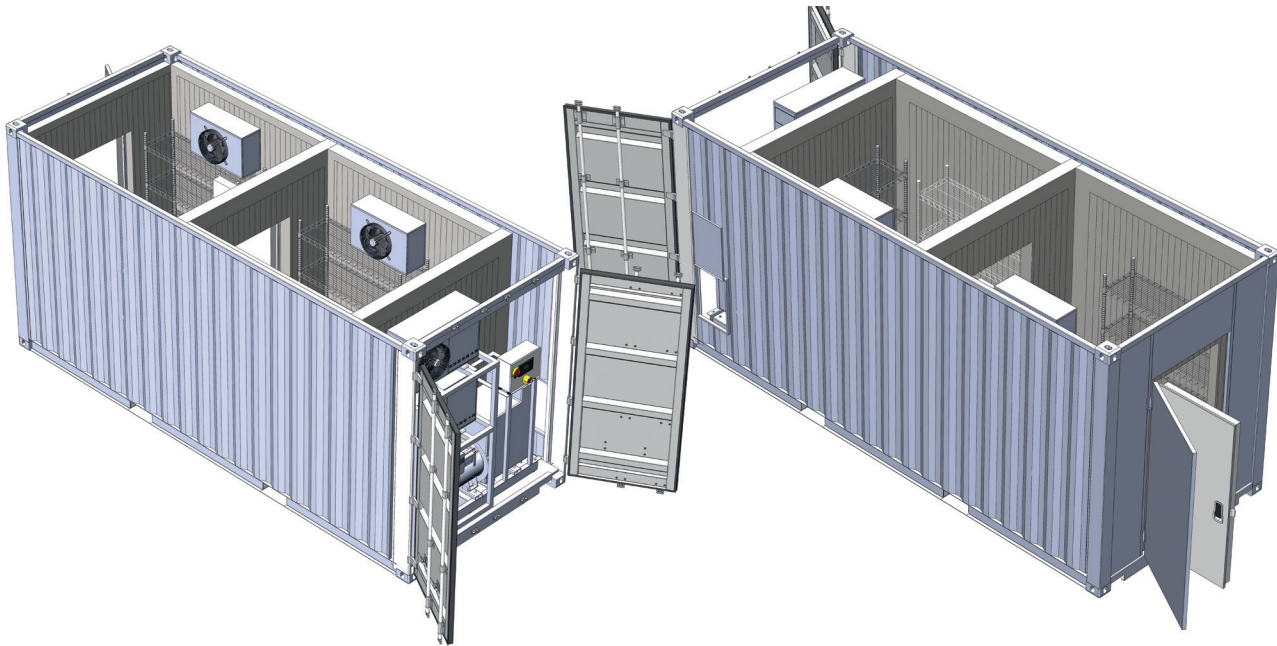

Generator

Information:

Diesel Generator: 20 kVA
Output Power: 20.3 kVA Prime
Dimensions (LxWxH): 650x1450x1150 mm
Engine: Perkins
No. of Cylinders: 4
Operating speed: 1500 rpm
Fuel Consumption: 6.1 Lt./h
Fuel Capacity: 75 Lt.

Freezer-Reefer Evaporator

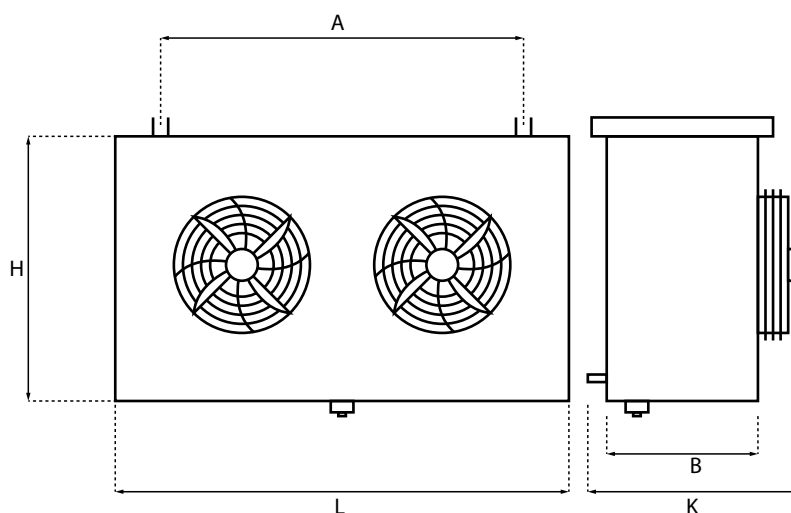

FREEZER					
MODEL	DIMENSIONS				
	A	L	H	K	B
KES 302	835 mm	1125 mm	430 mm	470 mm	290 mm

Information:

Evap Code: EDF-300

Evap Type: CUBIC

Evap Capacity: 3300 W.

Evap Supplier: Kontherm or Equal

REEFER					
MODEL	DIMENSIONS				
	A	L	H	K	B
KES 351	535 mm	815 mm	520 mm	470 mm	290 mm

Information:

Evap Code: ECR-200

Evap Type: CUBIC

Evap Capacity: 3850 W.

Evap Supplier: Kontherm or Equal

Freezer-Reefer condenser & compressor

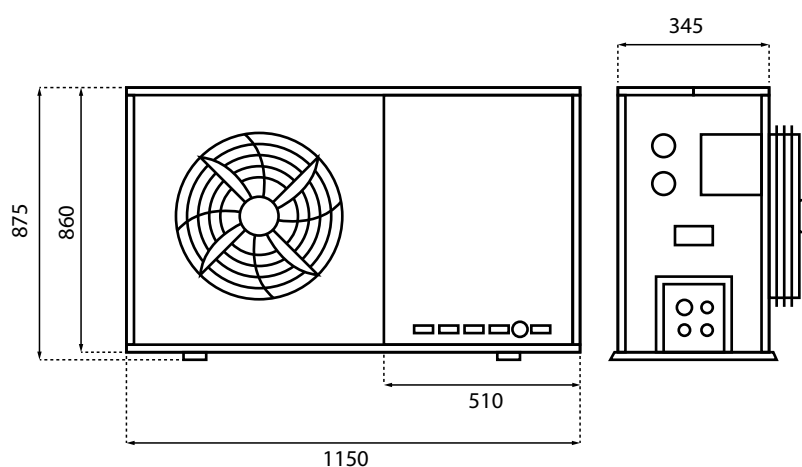

Freezer Information:

Compressor Brand: Bitzer / 3 hp Semi Hermetic

Compressor Type: Air

Cooling Capacity: 2891 W.

Reefer Information:

Compressor Brand: Bitzer / 2 hp Semi Hermetic

Compressor Type: Air

Cooling Capacity: 3178 W.

Evaporator



Condenser & Compressor



GENERAL TERMS

- All our products are guaranteed for 2 (Two) years against any manufacturing and installation defects.
- Our cooling units are being manufactured in Turkey under the brandname of OZTICOLD with CE certificates
- The units are fully automated with electrical defrosting and digital display (EVCO EVX 214 Made in ITALY)
- TECUMSEH /HERMETIC, COPELAND/SCROLL and BITZER brand name compressors, DANFOSS type expansion valves and fan controllers
- GUVEN liquid receivers and CASTEL dryer and selenoids are some of our major components we use in our units
- We have Schneider brand name automatic fuses, thermic relays and contactors as standart components on our switchboards
- Evaporators and units are electrostatically painted on galvanised sheets so having high endurance to corrosion
- All units are tested under 30 bar before being dispatched
- Unless otherwise specified all the units are due to 380V/3hp/50hz conditions
- In standart units max. +42 C°, and in tropic climate units an ambient temperature of +49 C° is considered
- All devices are sent together with their user manuals to assure their true usage and make an easy maintenance.
- The cooling fans are of EBM-PAPST brand or equal and comply with IP54 norms.
- The cold room evaporators are of KARYER, KONThERM, THERMOWAY or of an equivalent brand name.
- TECUMSEH /HERMETIC, COPELAND/SCROLL and BITZER/SEMI HERMETIC brand name compressors are preferred in the units.



40 Ft. Refrigerated containers are also
designed and produced

ztiryakiler

ztiryakiler Madeni EŖya San. ve Tic. A.Ŗ.

Cumhuriyet Mah. Eski Hadımky Yolu Cad. No.8 34500 Bykekmece - İstanbul / Trkiye

Tel: +90 (212) 886 78 10/11 (pbx) **Fax:** +90 (212) 886 62 36

www.ozti.com.tr

export@oztiryakiler.com.tr

ZTIRYAKILER reserves the right to change technical details, prices and models without previous notice.

All design rights are reserved. Reproduction or copying of the products in this catalogue, either full or in part is strictly forbidden without the prior permission of **ZTIRYAKILER**